

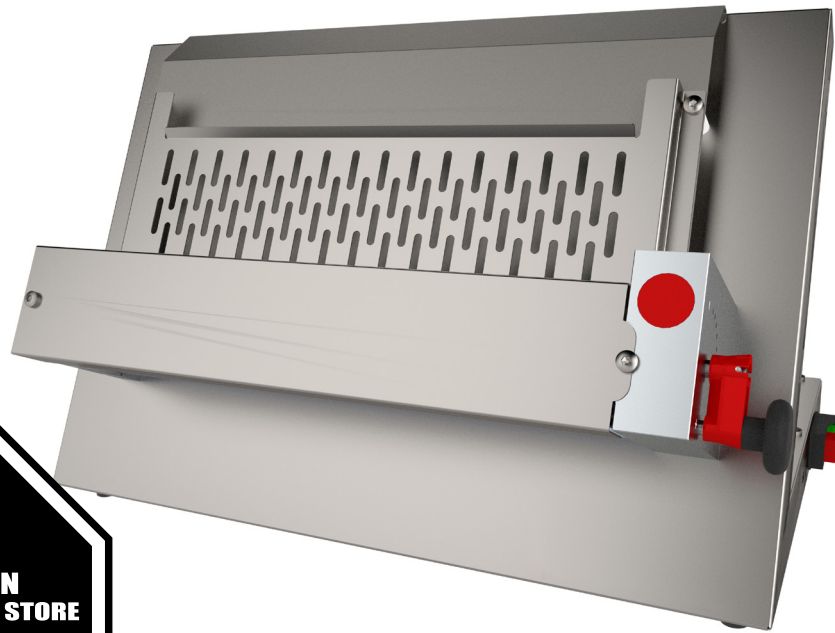

**Adjustable Dough Roller**  
Models BE-IT-0337, 0400  
Item 40639, 40640  
**Instruction Manual**



*Revised - 10/23/2023*



---

Toll Free: 1-800-465-0234  
Fax: 905-607-0234  
Email: [service@omcan.com](mailto:service@omcan.com)  
[www.omcan.com](http://www.omcan.com)



# ***Table of Contents***

Model BE-IT-0337 / Model BE-IT-0400

---

<b>Section</b>	<b>Page</b>
General Information -----	3 - 4
Safety and Warranty -----	4 - 7
Technical Specifications -----	7
Operation -----	7 - 9
Maintenance -----	10 - 11
Parts Breakdown -----	12 - 15
Electrical Schematics -----	16
Notes -----	17 - 18
Warranty Registration -----	19



# General Information

---

Omcan Manufacturing and Distributing Company Inc., Food Machinery of America, Inc. dba Omcan and Omcan Inc. are not responsible for any harm or injury caused due to any person's improper or negligent use of this equipment. The product shall only be operated by someone over the age of 18, of sound mind, and not under the influence of any drugs or alcohol, who has been trained in the correct operation of this machine, and is wearing authorized, proper safety clothing. Any modification to the machine voids any warranty, and may cause harm to individuals using the machine or in the vicinity of the machine while in operation.

## CHECK PACKAGE UPON ARRIVAL

Upon receipt of an Omcan shipment please inspect for external damage. If no damage is evident on the external packaging, open carton to ensure all ordered items are within the box, and there is no concealed damage to the machine. If the package has suffered rough handling, bumps or damage (visible or concealed), please note it on the bill of lading before accepting the delivery and contact Omcan within 24 hours, so we may initiate a claim with the carrier. A detailed report on the extent of the damage caused to the machine must be filled out within three days, from the delivery date shown in the shipping documents. Omcan has no recourse for damaged products that were shipped collect or third party.

**Before operating any equipment, always read and familiarize yourself with all operation and safety instructions.**

Omcan would like to thank you for purchasing this machine. It's of the utmost importance to save these instructions for future reference. Also save the original box and packaging for shipping the equipment if servicing or returning of the machine is required.

---

Omcan Fabrication et distribution Compañie Limité et Food Machinery d'Amérique, dba Omcan et Omcan Inc. ne sont pas responsables de tout dommage ou blessure causé du fait que toute personne ait utilisé cet équipement de façon irrégulière. Le produit ne doit être exploité que par quelqu'un de plus de 18 ans, saine d'esprit, et pas sous l'influence d'une drogue ou d'alcool, qui a été formé pour utiliser cette machine correctement, et est vêtu de vêtements de sécurité approprié. Toute modification de la machine annule toute garantie, et peut causer un préjudice à des personnes utilisant la machine ou des personnes à proximité de la machine pendant son fonctionnement.

## VÉRIFIEZ LE COLIS DÈS RÉCEPTION

Dès réception d'une expédition d'Omcan veuillez inspecter pour dommages externes. Si aucun dommage n'est visible sur l'emballage externe, ouvrez le carton afin de s'assurer que tous les éléments commandés sont dans la boîte, et il n'y a aucun dommage dissimulé à la machine. Si le colis n'a subi aucune mauvaises manipulations, de bosses ou de dommages (visible ou cachée), notez-le sur le bond de livraison avant d'accepter la livraison et contactez Omcan dans les 24 heures qui suivent, pour que nous puissions engager une réclamation auprès du transporteur. Un rapport détaillé sur l'étendue des dommages causés à la machine doit être rempli dans un délai de trois jours, à compter de la date de livraison indiquée dans les documents d'expédition. Omcan n'a aucun droit de recours pour les produits endommagés qui ont été expédiés ou cueilli par un tiers transporteur.

# ***General Information***

---

**Avant d'utiliser n'importe quel équipement, toujours lire et vous familiariser avec toutes les opérations et les consignes de sécurité.**

**Omcan voudrais vous remercier d'avoir choisi cette machine. Il est primordial de conserver ces instructions pour une référence ultérieure. Également conservez la boîte originale et l'emballage pour l'expédition de l'équipement si l'entretien ou le retour de la machine est nécessaire.**

---

**Omcan Empresa De Fabricacion Y Distribucion Inc. Y Maquinaria De Alimentos De America, Inc. dba Omcan y Omcan Inc. no son responsables de ningun daño o perjuicio causado por cualquier persona inadecuada o el uso descuidado de este equipo. El producto solo podra ser operado por una persona mayor de 18 años, en su sano juicio y no bajo alguna influencia de droga o alcohol, y que este ha sido entrenado en el correcto funcionamiento de esta máquina, y ésta usando ropa apropiada y autorizada. Cualquier modificación a la máquina anula la garantía y puede causar daños a las personas usando la máquina mientras esta en el funcionamiento.**

## **REVISE EL PAQUETE A SU LLEGADA**

Tras la recepcion de un envio Omcan favor inspeccionar daños externos. Si no hay daños evidentes en el empaque exterior, Habra el carton para asegurarse que todos los articulos solicitados estén dentro de la caja y no encuentre daños ocultos en la máquina. Si el paquete ha sufrido un manejo de poco cuidado, golpes o daños (visible o oculto) por favor anote en la factura antes de aceptar la entrega y contacte Omcan dentro de las 24 horas, de modo que podamos iniciar una reclamación con la compañía. Un informe detallado sobre los daños causados a la máquina debe ser llenado en el plazo de tres días, desde la fecha de entrega que se muestra en los documentos de envío. Omcan no tiene ningun recurso por productos dañados que se enviaron a recoger por terceros.

**Antes de utilizar cualquier equipo, siempre lea y familiarizarse con todas las instrucciones de funcionamiento y seguridad.**

**Omcan le gustaría darle las gracias por la compra de esta máquina. Es de la mayor importancia para salvar estas instrucciones para futuras consultas. Además, guarda la caja original y el embalaje para el envío del equipo si servicio técnico o devolución de la máquina que se requiere.**

# ***Safety and Warranty***

---

## **LEGAL WARRANTY**

The period of warranty is in agreement with the European community standards and starts from the date of the invoice issued at the time of purchase. Within such period all components that have unequivocal and well ascertained manufacturing flaws will be replaced or repaired free of charge exclusively by our plant. The guarantee does not include electrical components and those subject to wear and tear. Shipping and labour costs are not included in the warranty.

# Safety and Warranty

---

In order to make use of the legal warranty the user must strictly observe the instructions contained in this manual, as outlined in Directive 1999/44/CE, and more specifically:

- Always operate the roller according to its intended use.
- Always carry out constant and accurate maintenance.
- Allow only skilled and properly trained personnel to use the roller.

Failure to comply with the instructions provided in this manual will cause the warranty to be considered immediately null and void.

## SAFETY RECOMMENDATIONS

### WARNINGS FOR THE INSTALLER

Check that the location of the machine is in compliance with local, national and European regulations.

- Adhere to the instructions in this manual.
- Do not execute electrical connections using temporary or non insulated cables.
- Check that the ground connection of the electric system is working properly.
- Always use individual safety devices and other means of protection in compliance with the law.

### WARNING FOR THE USER

The conditions of the area where the machine is to be installed must have the following characteristics:

- The area must be dry.
- Water and heat sources must be at a safe and proper distance.
- Ventilation and lighting must be suitable and comply with the hygiene and safety standards foreseen by current laws.
- The floor must be flat and compact to facilitate thorough cleaning.
- There must be no obstacles of any kind in the immediate vicinity of the machine that could affect the machine's normal ventilation.

### In addition, the user must:

- Make sure to keep children away from the machine while it is operating.
- Adhere to the instructions in this manual.
- Not remove or tamper with the safety devices on the machine.
- Always pay careful attention to the work at hand and do not use the machine absentmindedly.
- Perform all operations with maximum safety and calm.
- Respect the instructions and warnings displayed on the machine labels.

The labels are accident prevention devices and must therefore always be perfectly legible. Should they be damaged and illegible, it is mandatory to replace them requesting replacements from the manufacturer.

- At the end of each working shift, disconnect electrical power before cleaning or doing any maintenance or transfer operations.

**WARNING: while the machine is under working, it is strictly forbidden to remove the security protections, because of the presence of moving parts which can cause hands crashing.**

**WARNING: RISK OF CRASHING COULD STILL REMAIN ALSO IF THE MACHINE IS EQUIPPED WITH**

# ***Safety and Warranty***

---

**A SAFETY PROTECTION. DON'T INTRODUCE ARTS OR ANY OTHER PARTS OF THE BODY TO THE INTERNAL PROTECTION OF THE ROLLS. TRAIN PERSONNEL TO USE THE MACHINE, BRINGING AWARE OF THE RISKS, IN ORDER TO AVOID DANGER OF DAMAGE TO PERSONS AND PROPERTY.**

## **WARNINGS FOR THE MAINTENANCE OPERATOR**

Observe the instructions indicated in this manual.

- Always use individual safety devices and other protection means.
- Before starting any maintenance operations, make sure that the machine, if it was used, has cooled down.
- Disconnect electrical power before intervening on electrical or electronic parts and connectors.
- If any of the safety devices is worn or faulty, the machine is also considered faulty and is not to be used.

## **MOVEMENT AND TRANSPORT**

The machine is provided with all necessary parts in a closed package attached to a wooden pallet with straps. The machine must be unloaded from the transport vehicle, lifting it with suitable equipment. To transport the machine to its installation area, use a rolling cart with suitable load capacity. During lifting operations, avoid sudden movements. Make certain that the lifting means have a load capacity that is superior to the weight of the machine to be lifted. The operator maneuvering the lifting equipment is responsible for lifting the load. Leave a free space of approximately 50cm around the machine to facilitate use, cleaning and maintenance operations.

## **DANGER**

Make sure that children do not play with the packaging materials (for example, plastic film and styrofoam). Suffocation danger!

**RESIDENTIAL USERS: vendor assumes no liability for parts or labor coverage for component failure or other damages resulting from installation in non-commercial or residential applications. The right is reserved to deny shipment for residential usage; if this occurs, you will be notified as soon as possible.**

## **1 YEAR PARTS AND LABOUR BENCH WARRANTY**

Within the warranty period, contact Omcan Inc. At 1-800-465-0234 to schedule a drop off to either an Omcan authorized service depot in the area, or to an Omcan Service warehouse to repair the equipment.

Unauthorized maintenance will void the warranty. Warranty covers electrical and part failures, not improper use.

Please see <https://omcan.com/disclaimer> for complete info.

## **WARNING:**

The packaging components are classified as normal solid urban waste and can therefore be disposed of without difficulty.

# Safety and Warranty

In any case, for suitable recycling, we suggest disposing of the products separately (differentiated waste) according to the current norms.

**DO NOT DISCARD ANY PACKAGING MATERIALS IN THE ENVIRONMENT!**

## Technical Specifications

### MAIN TECHNICAL PARAMETERS

Model	BE-IT-0337	BE-IT-0400
Dough Weight	80g / 400g	210g / 600g
Pizza Diameter	5.5" - 13.4" / 140 - 340mm	10.2" - 15.7" / 260 - 400mm
Volume	0.18 m <sup>3</sup> / 6.3 cu.ft.	0.29 m <sup>3</sup> / 10.2 cu.ft.
Power	0.5 HP	
Electrical	110-120V / 60Hz / 1	
Dimensions	19.7" x 15.8" x 17.7" 500 x 401 x 450mm	22.4" x 17.7" x 15.7" 569 x 450 x 399mm
Packaging Dimensions	31.9" x 26.4" x 20.9" 810 x 671 x 531mm	26.8" x 20.1" x 20.9" 681 x 511 x 531mm
Weight	48.5 lbs. / 22 kgs.	57.3 lbs. / 26 kgs.
Packaging Weight	57.3 lbs. / 26 kgs.	66.1 lbs. / 30 kgs.
Item Number	40639	40640

## Operation

### PREPARATION OF THE INSTALLATION AREA

#### SAFETY PRECAUTIONS

Responsibility for operations executed in the room where the machine is installed is and remains of the user.

- The user is also responsible for the execution of controls related to the installation of the machine.
- The user must comply with all local, national and European safety regulations.
- The equipment must be installed on floors with adequate load capacity.
- The assembly and disassembly instructions for the rolling machine are intended for specialized technicians.
- It is always recommended that users contact our assistance service for technical requests.
- Prior to starting machine assembly or disassembly, the installer must respect safety precautions in compliance with the law, and in particular must:

# Operation

1. Not operate in unfavorable conditions.
2. Operate in perfect psycho-physical conditions and check that the individual accident prevention devices work perfectly.
3. Wear accident prevention gloves.
4. Wear accident prevention footwear.
5. Use electrically insulated tools.
6. Make sure that the area used for assembly and disassembly is free of any obstacles.

## INSTALLATION'S LOCATION

The picture below shows the minimum distances that must be respected when positioning the machine in order to facilitate its use, cleaning and maintenance.

The minimum distance between the machine and surrounding walls or other devices must be of approximately 50 cm.

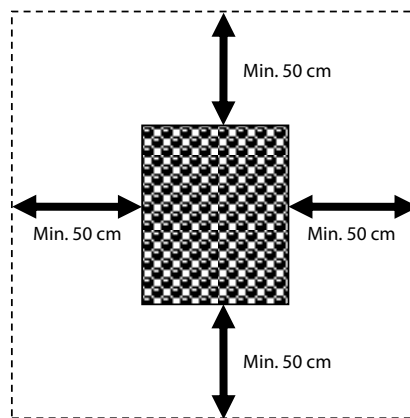

## INSTALLATION

Installation must be executed by qualified personnel in compliance with local, national and European regulations.

## MACHINE POSITIONING

Ensure that the machine is put on a flat stand with a suitable carrying capacity. After unpacking the rolling machine, put it in the prepared location, keeping in mind the minimum distances to be respected. Remove any polystyrene protections and take off the protecting film. Avoid using tools which might damage the surfaces.

## EQUIPMENT HOOK-UP

### ELECTRICAL CONNECTION

Just connect the electricity-supply cable to the electricity network. The electrical outlet must be easily accessible, no moving should be necessary. The electrical connection (plug) must be easily accessible, also after roller installation. The distance between the roller and the socket must be suitable, as not to cause tension in the power supply cable. The cable, moreover, must not be located beneath the machine support base.

**If the electrical power supply cable is damaged, it must be replaced by the technical assistance service**



or by a qualified technician to prevent any risks.

Ground connection It is mandatory that the electrical system is equipped with a ground connection.

## MACHINE START UP AND USE

### CONTROL BOARD DESCRIPTION

Our rolling machines are provided with an electronic start/stop circuit board with control treadle (except for RM32AE, RM42AE, RM42TAE and M35 models, which do not have a treadle). The picture below shows the board's control buttons.

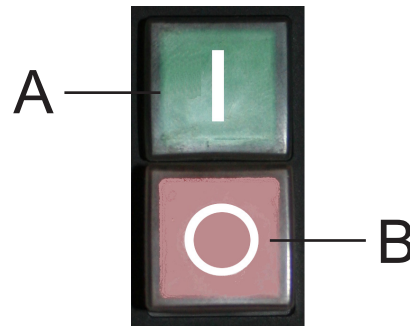

A) START – start rollers.

B) STOP – stop rollers.

### WORKING PHASE

#### Models with parallel rollers (rectangle shaping)

Put a clean baking-tin under the rolling machine. It should be big enough to adapt to the steel feet.

- Press the control treadle to set the machine rollers going (for models without treadle push the START button on the circuit board to start the machine and the STOP button to stop it.)
- Position the dough ball so that it passes smoothly through the top rollers (shape one side like a wedge to simplify the operation).
- After this step the dough thickness is reduced.
- For intermediate and high weighed dough discs it is then necessary to keep spreading the dough by hand, accompanying it towards the lower rollers, until the dough comes out and falls onto the baking-tin.

**N.B. in the single roller models (M35) the dough is pressed just once, as there is just one roller.**

### SHUT DOWN PHASE

To turn off the machine release the control treadle (in the models provided with it) or push the STOP button (in the models without treadle).

# Maintenance

---

## MAINTENANCE AND CLEANING

### SAFETY PRECAUTIONS

- Before performing any maintenance operations take the following precautions:
- Ensure that the machine is not working and that it has completely cooled down.
- Ensure that the machine is disconnected from electricity supply.
- Make certain that the electrical power cannot be accidentally reconnected. Disconnect the plug from the socket.
- Use individual protection devices in compliance with the directive 89/391/EEC.
- Always use appropriate maintenance tools.
- Once maintenance and repairs are finished, reinstall all protection devices and reactivate all safety devices before starting up the machine again.

### ROUTINE MAINTENANCE FOR THE USER

- As any equipment, also our machines require a simple yet frequent and careful cleaning to ensure an effective and regular functioning.
- It is recommended to never use abrasives, corrosives or chemical products which are not specific for food preparation areas. Avoid by all means using water jets, unspecific tools.
- Rough or abrasive instruments, such as steel wool or sponges or any other item which could damage the machine surface, especially those which could jeopardize health safety.
- Using a suitable brush, perform a first removal of flour and dough remainders.
- Remove the two protections, the balancing device and the chutes.
- Release the dough scraper springs.
- Pull out the dough scrapers.
- Turn the regulation levers opening the rollers to their maximum extent.
- Clean the machine and all the removed components using a sponge or cloth moistened with water and detergent.
- Carefully rinse until the detergent is completely removed.
- Dry with kitchen paper and then first go over the surfaces in contact with the dough and then the whole machine with a soft, clean cloth soaked with a disinfectant suitable for food processing machines.

### MAINTENANCE ADDRESSED TO QUALIFIED

- Shafts and rollers must be lubricated once a year.
- Remove protections, chutes, springs and dough scrapers.
- Remove the back (loosen the locking screws).
- Then remove supports.
- Pull out rollers and joints.
- Clean all parts thoroughly using a sponge, warm water and a food grade detergent.
- Rinse sufficiently and dry with absorbent paper.
- Lubricate both shafts and rollers' holes with a suitable quantity of paraffin oil.
- Re-assemble and fix all previously removed components, working in the inverse order.

### DEMOLITION AND DISPOSAL INFORMATION

Demolition and disposal of the machine are the sole responsibility of the owner, who must perform these tasks in compliance with the currently safety and environmental protection rules enforced in the country where the

# Maintenance

---

machine is installed. Disassembly and disposal can also be performed by a third party, as long as it is an authorized company for the recovery and demolition of the materials in question.

## **INSTRUCTION**

Always adhere to the laws concerning the disposal of materials and, if needed, the disposal registration, currently enforced in the country where the machine is installed.

**WARNING: all disassembly operations for demolition must take place when the machine is off and disconnected from the electrical power supply.**

- Remove all electric system components.
- Separate the accumulators of the electronic cards.
- Dispose of the machine frame through authorized companies.

**WARNING: abandoning the machine in accessible areas seriously jeopardizes people and animals. Responsibility for possible damage to people and animals falls exclusively on the owner.**

## **USER INFORMATION**

This appliance is to be disposed of in compliance with the European directive 2002/96/EC, stating that this product must be disposed of separately from normal house waste. A suitable waste disposal and thus a correct recycling of the exhausted machine contribute avoiding a possible negative impact on environment and on health, while fostering the reuse or recycling of the equipment materials. For further information about the disposal centres, please contact your local waste management office or your dealer.

# Parts Breakdown

Model **BE-IT-0337** 40639

Model **BE-IT-0400** 40640

**Complete Unit**

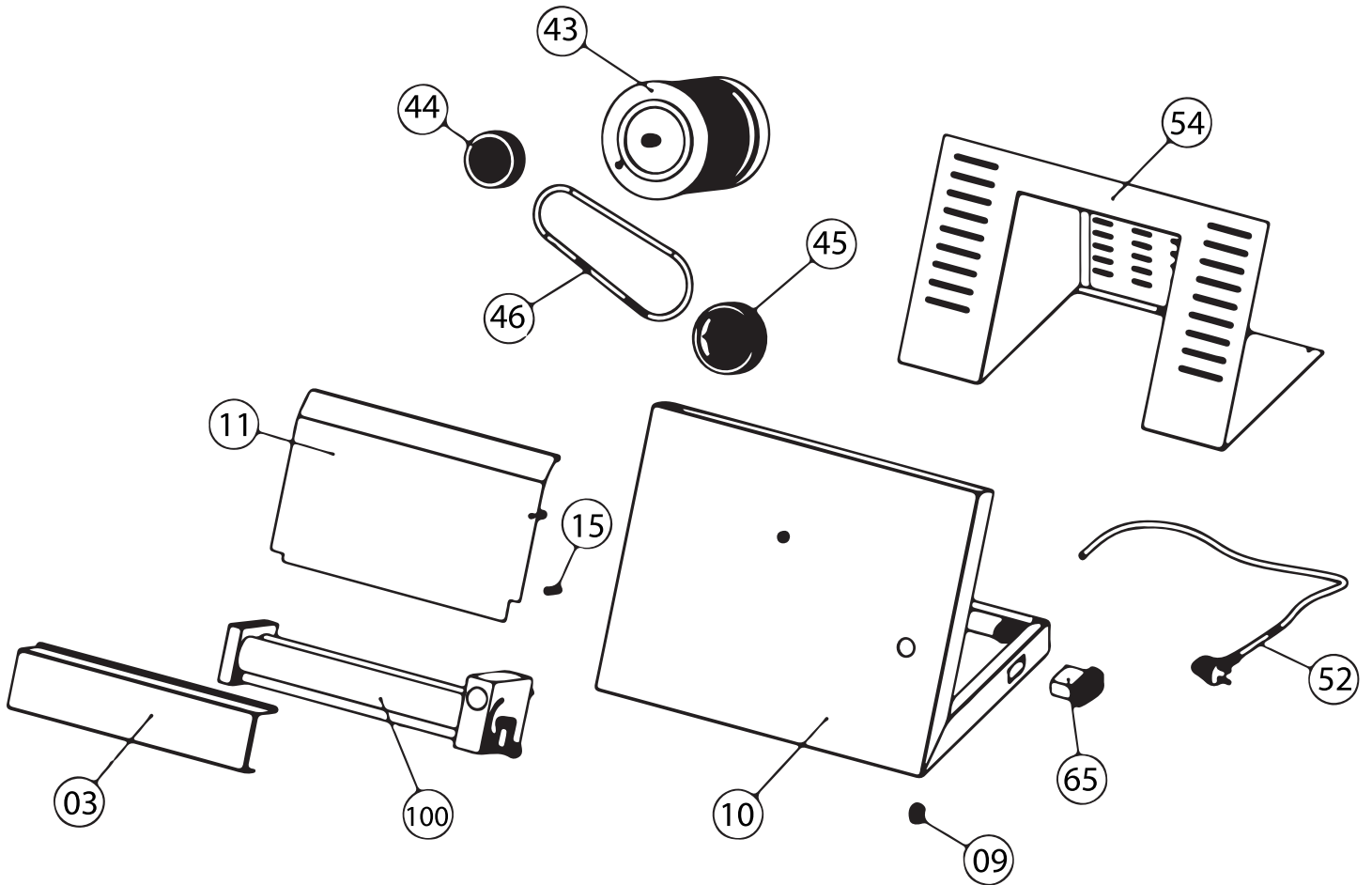

# Parts Breakdown

**Model BE-IT-0337** 40639  
**Model BE-IT-0400** 40640

**Lower Rolling Unit**

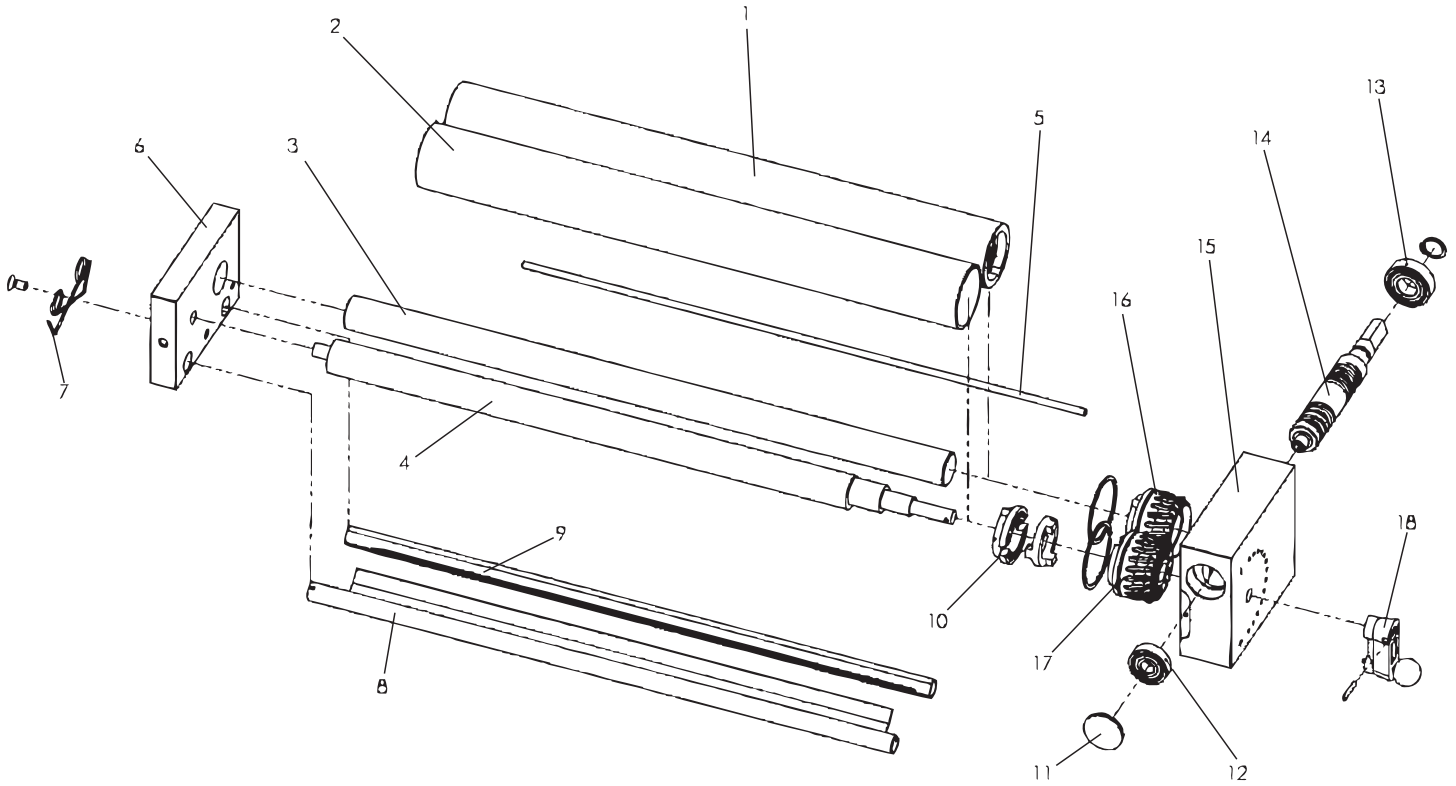

# Parts Breakdown

**Model BE-IT-0337** 40639

**Complete Unit**

Item No.	Description	Position	Item No.	Description	Position	Item No.	Description	Position
63576	Rear Guard for 40639	03	63580	Motor 110V-60Hz 0.25kW-0.33HP B5 for 40639	43	63581	Motor Casing Assembly for 40639	54
79651	Black Corner Foot Rivet for 40639	09	63557	Plastic Motor Pulley for 40639	44	AO319	KLD-28A Start/Stop Green/Red Button for 40639	65
63577	Steel Enclosure for 40639	10	63558	Plastic Reduction Pulley for 40639	45	63180	Lower Roller Unit (Grey) for 40639	100
63578	Steel Slide for 40639	11	60331	Belt 8x560 for 40639	46			
63554	10x37 Upper Spacer for 40639	15	63560	Feed Cable SJT3X14AWG for 40639	52			

## Lower Rolling Unit

Item No.	Description	Position	Item No.	Description	Position	Item No.	Description	Position
63582	Lower Cylindrical Roller 1 for 40639	1	79650	Pizza Dough Scraper Spring for 40639	7	63573	6202 ZZ Bearing 1 for 40639	13
63583	Lower Eccentric Roller 1 for 40639	2	63569	Front Aluminum Pizza Dough Scraper 1 for 40639	8	63574	Cylindrical Screw (Rolls Center Distance of 50) for 40639	14
63584	Lower Cylindrical Shaft 1 for 40639	3	63570	Back Aluminum Pizza Dough Scraper 1 for 40639	9	63575	Lower Reduction Gear Support 1 for 40639	15
63585	Lower Eccentric Shaft 1 for 40639	4	79646	Male/Female Group Joint for 40639	10	79647	Cylindrical Gear for 40639	16
63567	5x438 Steel Rod 1 for 40639	5	63571	Red Ral 3020 Cap 1 for 40639	11	79648	Eccentric Gear for 40639	17
63568	Lower Small Support 1 for 40639	6	63572	6200 ZZ Bearing 1 for 40639	12	79649	Thickness Adjustment Group (Red) for 40639	18

# Parts Breakdown

**Model BE-IT-0400** 40640

**Complete Unit**

Item No.	Description	Position	Item No.	Description	Position	Item No.	Description	Position
63551	Rear Guard for 40640	03	63556	Motor 110V-60Hz 0,37kW-0,5HP B5 for 40640	43	63561	Motor Casing Assembly for 40640	54
79651	Black Corner Foot Rivet for 40640	09	63557	Plastic Motor Pulley for 40640	44	AO319	KLD-28A Start/Stop Green/Red Button for 40640	65
63552	Steel Enclosure for 40640	10	63558	Plastic Reduction Pulley for 40640	45	49502	Lower Roller Unit Red Ral 3020 for 40640	100
63553	Steel Slide for 40640	11	79653	Belt 8x680 for 40640	46			
63554	10x37 Upper Spacer for 40640	15	63560	Feed Cable SJT3X14AWG for 40640	52			

## Lower Rolling Unit

Item No.	Description	Position	Item No.	Description	Position	Item No.	Description	Position
63563	Lower Cylindrical Roller 1 for 40640	1	79650	Pizza Dough Scraper Spring for 40640	7	63573	6202 ZZ Bearing 1 for 40640	13
63564	Lower Eccentric Roller 1 for 40640	2	63569	Front Aluminum Pizza Dough Scraper 1 for 40640	8	63574	Cylindrical Screw (Rolls Center Distance of 50) 1 for 40640	14
63565	Lower Cylindrical Shaft 1 for 40640	3	63570	Back Aluminum Pizza Dough Scraper 1 for 40640	9	63575	Lower Reduction Gear Support 1 for 40640	15
63566	Lower Eccentric Shaft 1 for 40640	4	79646	Male/Female Group Joint for 40640	10	79647	Cylindrical Gear for 40640	16
63567	5x438 Steel Rod 1 for 40640	5	63571	Red Ral 3020 Cap 1 for 40640	11	79648	Eccentric Gear for 40640	17
63568	Lower Small Support 1 for 40640	6	63572	6200 ZZ Bearing 1 for 40640	12	79649	Pizza Dough Roll Mach Thickness Adjustment Group (Red) for 40640	18

# Electrical Schematics

Model **BE-IT-0337** 40639

Model **BE-IT-0400** 40640

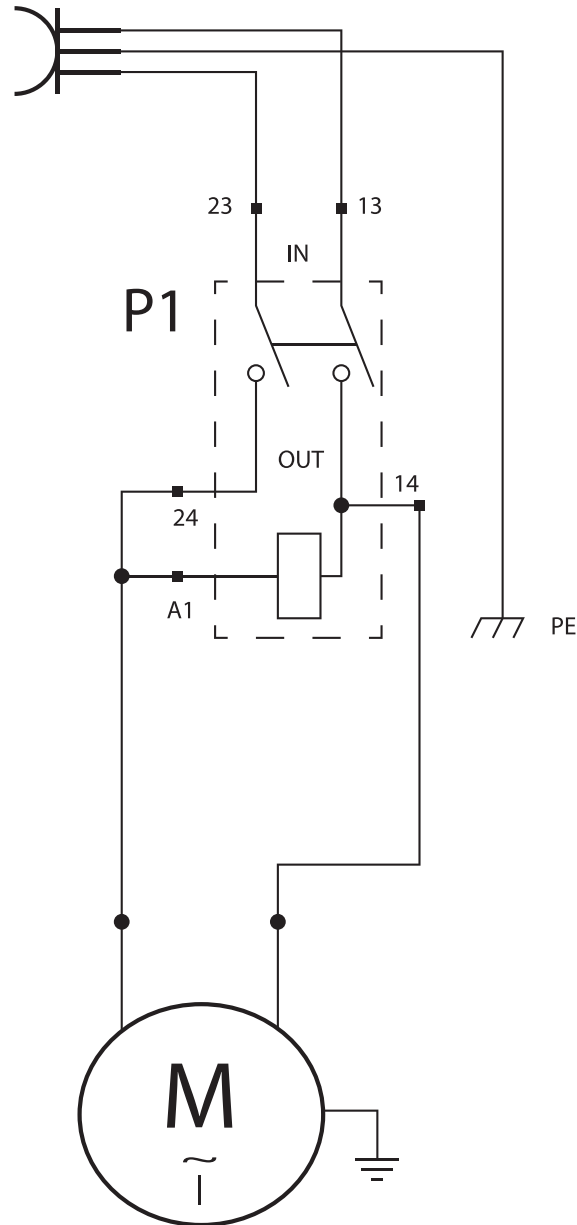

**NEMA**  
5 - 15P  
125VAC / 15 AMP









# Warranty Registration

Thank you for purchasing an Omcan product. To register your warranty for this product, complete the information below, tear off the card at the perforation and then send to the address specified below. You can also register online by visiting:

Merci d'avoir acheté un produit Omcan. Pour enregistrer votre garantie pour ce produit, complétez les informations ci-dessous, détachez la carte au niveau de la perforation, puis l'envoyer à l'adresse spécifiée ci-dessous. Vous pouvez également vous inscrire en ligne en visitant:

Gracias por comprar un producto Omcan usted. Para registrar su garantía para este producto, complete la información a continuación, cortar la tarjeta en la perforación y luego enviarlo a la dirección indicada a continuación. También puede registrarse en línea en:

<https://omcan.com/warranty-registration/>

For mailing in Canada

Pour postale au Canada

Por correo en Canadá

**OMCAN**

PRODUCT WARRANTY REGISTRATION

3115 Pepper Mill Court,

Mississauga, Ontario

Canada, L5L 4X5

For mailing in the US

Pour diffusion aux États-Unis

Por correo en los EE.UU.

**OMCAN**

PRODUCT WARRANTY REGISTRATION

4450 Witmer Industrial Estates, Unit 4,

Niagara Falls, New York

USA, 14305

*or email to: [service@omcan.com](mailto:service@omcan.com)*



Purchaser's Information

Name: \_\_\_\_\_

Address: \_\_\_\_\_

City: \_\_\_\_\_ Province or State: \_\_\_\_\_ Postal or Zip: \_\_\_\_\_

Country: \_\_\_\_\_

Dealer from which Purchased: \_\_\_\_\_

Dealer City: \_\_\_\_\_ Dealer Province or State: \_\_\_\_\_

Invoice: \_\_\_\_\_

Model Name: \_\_\_\_\_ Model Number: \_\_\_\_\_

Machine Description: \_\_\_\_\_

Date of Purchase (MM/DD/YYYY): \_\_\_\_\_

Would you like to extend the warranty?  Yes  No

Company Name: \_\_\_\_\_

Telephone: \_\_\_\_\_

Email Address: \_\_\_\_\_

Type of Company:

Restaurant  Bakery  Deli

Butcher  Supermarket  Caterer

Institution (specify): \_\_\_\_\_

Other (specify): \_\_\_\_\_

Serial Number: \_\_\_\_\_

Date of Installation (MM/DD/YYYY): \_\_\_\_\_

**Thank you for choosing Omcan | Merci d'avoir choisi Omcan | Gracias por elegir Omcan**



Since 1951 Omcan has grown to become a leading distributor of equipment and supplies to the North American food service industry. Our success over these many years can be attributed to our commitment to strengthen and develop new and existing relationships with our valued customers and manufacturers. Today with partners in North America, Europe, Asia and South America, we continually work to improve and grow the company. We strive to offer customers exceptional value through our qualified local sales and service representatives who provide convenient access to over 6,500 globally sourced products.

---

Depuis 1951 Omcan a grandi pour devenir un des “leaders” de la distribution des équipements et matériel pour l’industrie des services alimentaires en Amérique du Nord. Notre succès au cours de ces nombreuses années peut être attribué à notre engagement à renforcer et à développer de nouvelles et existantes relations avec nos clients et les fabricants de valeur. Aujourd’hui avec des partenaires en Amérique du Nord, Europe, Asie et Amérique du Sud, nous travaillons continuellement à améliorer et développer l’entreprise. Nous nous efforçons d’offrir à nos clients une valeur exceptionnelle grâce à nos ventes locales qualifiées et des représentants de service qui offrent un accès facile à plus de 6500 produits provenant du monde entier.

---

Desde 1951 Omcan ha crecido hasta convertirse en un líder en la distribución de equipos y suministros de alimentos en América del Norte industria de servicios. Nuestro éxito en estos años se puede atribuir a nuestro compromiso de fortalecer y desarrollar nuevas relaciones existentes con nuestros valiosos clientes y fabricantes. Hoy con socios de América del Norte, Europa, Asia y América del Sur, que trabajan continuamente para mejorar y crecer la empresa. Nos esforzamos por ofrecer a nuestros clientes valor excepcional a través de nuestro local de ventas y representantes de los servicios que proporcionan un fácil acceso a más de 6,500 productos con origen a nivel mundial.

